

S5400P

2004-2006 NISSAN TITAN, 5.6L, KING CAB (6.5' BOX) / CREW CAB (6' BOX),
3" CAT BACK, SINGLE SIDE

MBRP®

June 16, 2020

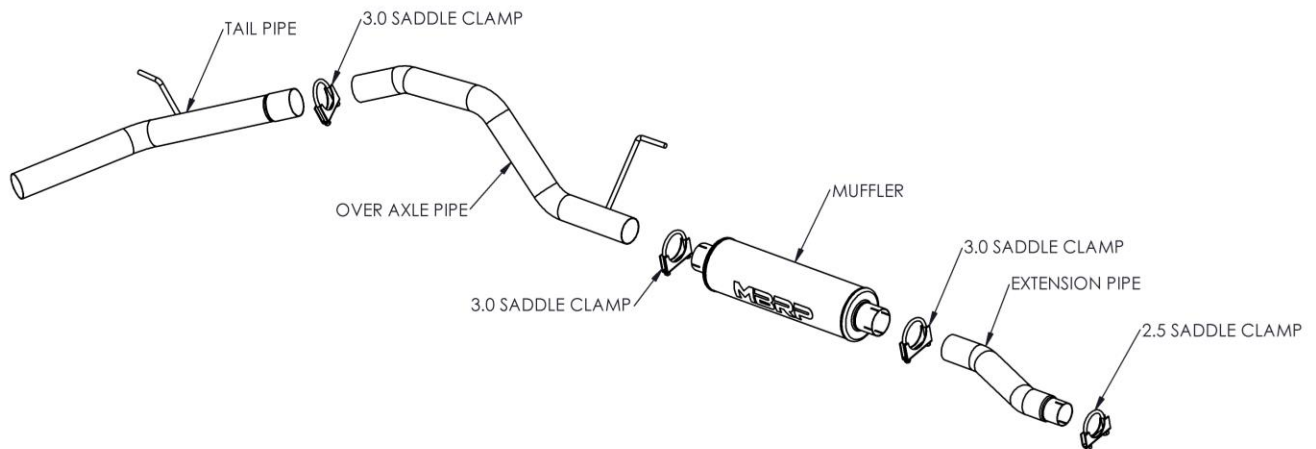

PLEASE READ BEFORE STARTING INSTALLATION

MBRP has made every effort to ensure that all components of this system are of superior quality and properly packaged. It is the installer's responsibility to ensure that all components are present and fit together as shown. Please also ensure that all components are undamaged before removal of the factory exhaust. Finally, check that this system properly matches the make and model of the vehicle and will not interfere with previous or planned modifications.

Removal of stock system:

1. Apply a penetrating lubricant liberally to all exhaust fasteners, hangers and rubber insulators.
2. Mark 8" from the outside of the vehicle stock hanger just after the Y pipe.
3. Cut the pipe at the mark. Remove any burrs on the cut pipe.
4. Lubricate then remove the hardware from the rearmost exhaust hanger. Keep for reinstallation.
5. Remove the hardware from the flange behind the muffler. Remove the hangers from the rubber insulators and remove the exhaust from the vehicle.

Installation of MBRP Performance Exhaust:

1. Install the **Extension Pipe** over the cut exhaust pipe using a **2.5" Band Clamp**.
2. Slide a **3" Band Clamp** over the **Extension Pipe** and install the **Muffler** onto the **Extension Pipe**.
3. Slide a **3" Band Clamp** over the outlet side of the **Muffler**. Position the **Over Axle Pipe** over the axle and loosely attach it to the **Muffler**. Install the **Over Axle Pipe** hanger into the factory rubber insulator.
4. Slide a **3" Band Clamp** over the **Tail Pipe** and it install onto the **Over Axle Pipe**. Slide the **Tail Pipe** hanger into the rearmost rubber insulator and reattach it to the frame.
5. Align the exhaust as required. Starting at the front of the exhaust, tighten all clamps and connections.
6. Carefully position the ABS line to provide clearance to the exhaust.
7. Tighten all hardware and clamps, starting at the front and working rearward to secure the system. Check along the full length of the exhaust system to ensure there is adequate clearance for fuel lines, vent lines, brake lines, frame, bodywork, suspension, and any wiring, etc. If there is any interference detected, relocate, or adjust to provide adequate clearance. Ensure all clamp connections are secure and components are unable to rotate or slide. Band clamps require approximately 45 lb-ft (60 N-m) of torque. Verify clearances, system security and band clamp torque after 30-60 miles (50-100 km) of driving.

Congratulations! You are ready to begin enjoying the improved performance and driving experience of your **MBRP** Performance Exhaust system.
We hope you enjoy your purchase.