

AT-7301

UTILITY MUFFLER - SLIP- ON, SUZUKI
1990-2001 LTF 250 2X4 QUADRUNNER
1987-1997 LTF 250 4WD QUADRUNNER
1991-1998 LTF 4WDX KING QUAD
1999-2002 LTF 300F KING QUAD

MBRP

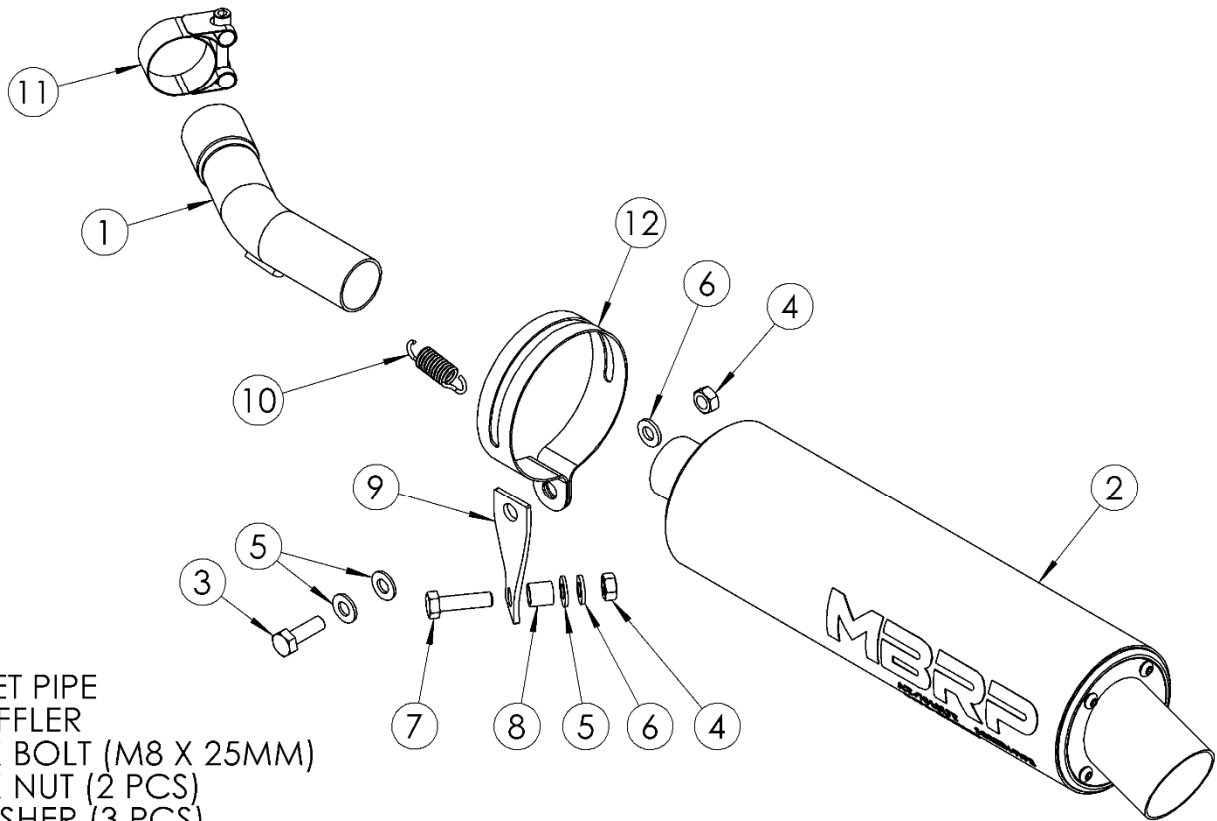

1. INLET PIPE
2. MUFFLER
3. HEX BOLT (M8 X 25MM)
4. HEX NUT (2 PCS)
5. WASHER (3 PCS)
6. LOCK WASHER (2 PCS)
7. HEX BOLT (M8 X 30MM)
8. SPACER
9. TWISTED BRACKET
10. EXTENSION SPRING
11. CLAMP
12. MUFFLER BAND

PLEASE READ BEFORE STARTING INSTALLATION

While MBRP has made every effort to ensure that all components of this system are of superior quality and properly packaged, it is the installer's responsibility to ensure the following before removal of the factory exhaust:

- that ALL components shown above are present.
- that ALL mating components fit together.
- that there are no damaged components.
- that the system you have purchased is appropriate for your vehicle year, model and configuration.
- that the system will not interfere with any modifications previously installed or planned.
- that you have read and understand these instructions.

If you have any questions or are uncertain about any aspect of the installation of this system to your vehicle please contact your dealer before commencing installation.

MBRP

Removal of Stock Exhaust:

1. Remove the rear portion of the heat shield that wraps around the clamp joining the head pipe to the muffler (**Figure 1**).
2. Loosen the original clamp on the muffler.
3. Remove the two bolts (each side) at the bottom of the muffler holding it to the frame.
4. Remove the 4 bolts holding the heat shield on top of the muffler (**Figure 2**). This stays in the bike but has to be loose to remove the original muffler.
5. Pull the muffler out of the rear of the bike.
6. Remove the top left bolt from the hitch mount (**Figure 2**).

Installation of MBRP Exhaust:

1. Slide the **Inlet Pipe** into the expanded end of the **Muffler** so that the **Spring** mounts line up on both.
2. Install the **Spring**.
3. Install the **Clamp** over the new **Inlet Pipe** now.
4. With the original metallic gasket removed, slide the **Muffler** in from the rear of the bike until the **Inlet Pipe** slides over the original head pipe. (The new exhaust system does not use the original clamp or the metallic gasket at the slip joint as the **Inlet Pipe** is expanded to go snugly over the head pipe.)
5. The **Muffler** and the **Inlet Pipe** can then be twisted slightly so that no part of the new exhaust touches the frame. Bolt the **Twisted bracket** to the hitch mount. Slide the **Muffler Band** over the muffler and bolt it to the **Twisted bracket**.
6. Install the heat shield.
7. Install the **M8 x 30mm Hex bolt** and the **M8 x 25mm Hex bolt** holding the top heat shield.

Congratulations! You are ready to begin experiencing the improved performance and driving excitement of your MBRP Ltd. Exhaust upgrade. We know you will enjoy your purchase.

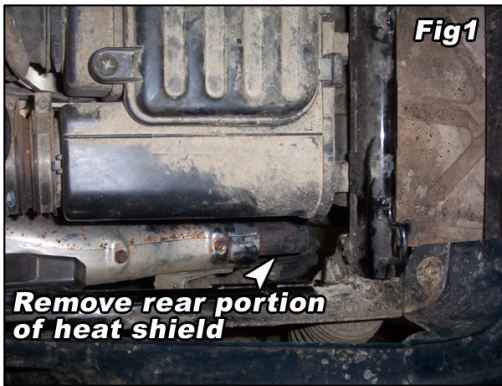

Figure 1

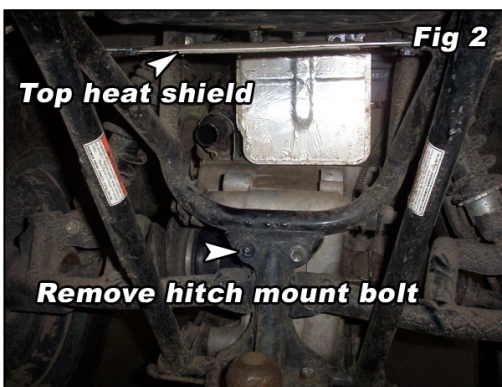

Figure 2



Figure 3